

YTONG Slab Panel

YTONG Slab Panels are manufactured under the most stringent quality controls. The lightweight and high strength characteristics make YTONG Slab Panels ideally suitable for high-rise reinforced concrete and structural steel frame buildings.

YTONG Slab Panels are dimensionally precise and extremely light weight so installation is simple and fast. Also, no formwork is required. YTONG panels are ready to be erected at the time of delivery which reduces quality control on-site.

Reinforcement

The amount of reinforcement required is determined by the span, panel thickness and loading conditions. All slab panels are load tested and fully comply with the stipulations of the building (construction) regulation.



Panel Layout



The use of standard width panels is recommended for the panel layout design wherever possible, different lengths of panel should be minimized. A large variety of panel sizes will not be economical and create confusion on site. It is not advisable to use panels with less than 300mm width.

Slab Panel Finishes

The purpose of floor finishing is to provide protection against wearing, impact, concentrated loading and water infiltration. Floor finishing provides the added advantages of reducing sound and heat transmission, countering high humidity and finally an attractive appearance.

Consequently, the selected floor finishing needs to be durable, lightweight, excellent ability to wear, a dampener of vibration and also suitable for the functional use of the area it covers.



Product Data

Product	Standard Dimensions		
	Width (mm)	Length (mm)	Thickness (mm)
YTONG AAC Slab Panel	600 ± 3	Up to 3000mm (refer to the Design Load)	150 ± 1.5

Technical Data

Density (Dry Weight)	Shrinkage	Compressive Strength	Thermal Conductivity	Fire Resistance Period (min.)
600 kg/m ³ ± 50	0.05%	5.0MPa ± 0.5	0.16W/m K	120 / 120 / 120 *

* Comply with BS EN 1365-2: 2014 with respect to terms loading capacity (stability) / integrity / insulation

Typical Drawing

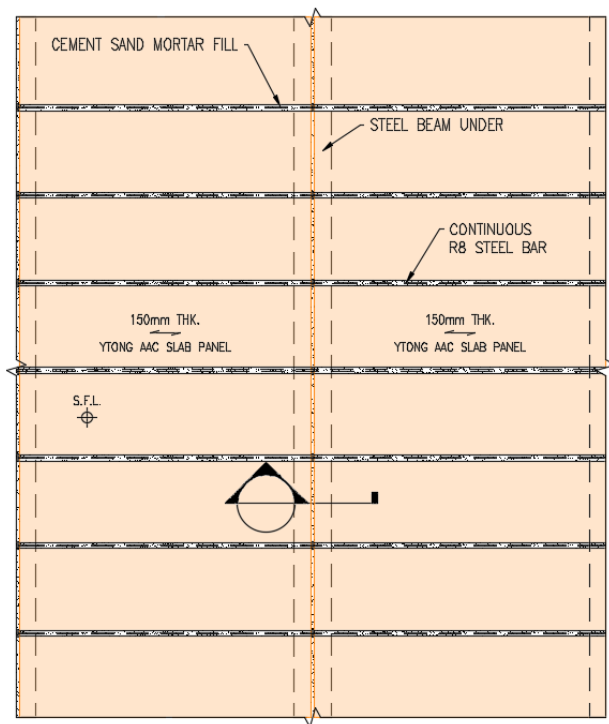

○ GENERAL PLAN

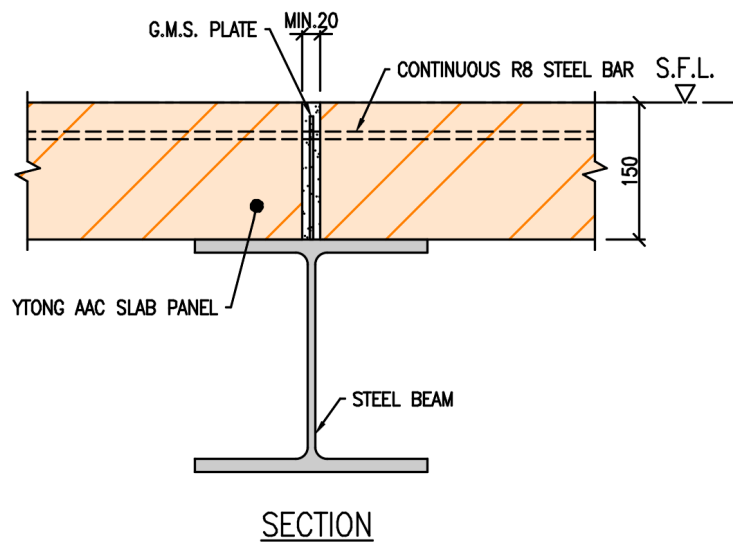

SECTION

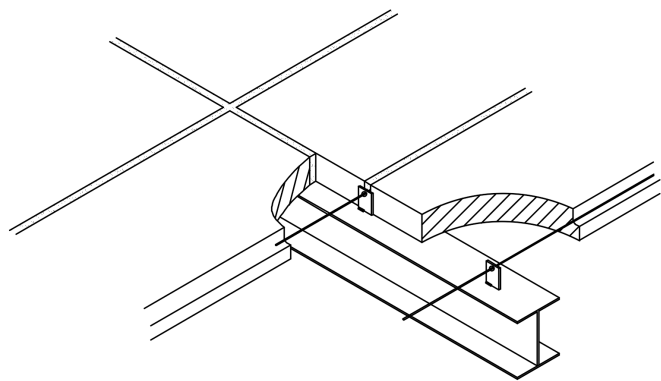

ISOMETRIC VIEW

捷威建材有限公司
Jetway Building Material Ltd.

香港九龍新蒲崗六合街25號嘉時工廠大廈18樓A座
Unit A, 18/F., Galaxy Factory Building,
25 Luk Hop Street, San Po Kong, Kowloon, Hong Kong
Tel : +852 - 3460 4340 Fax: +852 - 3460 4341
www.jetwaybm.com info@jetway-bm.com